



2018.05.31

" "

" "



0755-23976830

0755-23976213



baoyanxin@gtjas.com

qishuyang@gtjas.com

S0880513070005

S0880116040064

⌂

" "

002271

⌂

1.0-1.5% 2017

1060

20%

2000 /

90%

17 12

598

1500

2000

65.1%

7%

SBS/APP

27%

1000 /

50%

⌂

" "

0.6

2017

100%

1.	" "	3
2.		4
2.1.1.		4
2.1.2.		5
2.1.3.		6
2.1.4.		8
3.		10
3.1.		10
3.2.	ROE		
	12		
4.	——	15
4.1.		15
4.2.		20
5.		22
6.		24
6.1.		24
6.2.		26
6.2.1.		26
6.2.2.		28

1.

" "

□ 1.0-1.5%

2017 1060 20%

2000 / 90% 17 12

598 1500

CR50 23%(CR5 12%)

10% 60%

□

2000 65.1% 7% SBS/APP

27%

1000 /

50%

□ A

4

□ " "

0.6 2017

40%

ROE 10%

ROE

2

□

PPG SHW

"

"

□

2008

PE

20~30

7

PE

20-40

15-20

08

PE

15-20

PPG SHW VAL

20-30

2.

2.1.1.

1-1.5% 2017

2000

1060

20%

2016 340.4 -9%

123.1 36.1% 10

30%

4

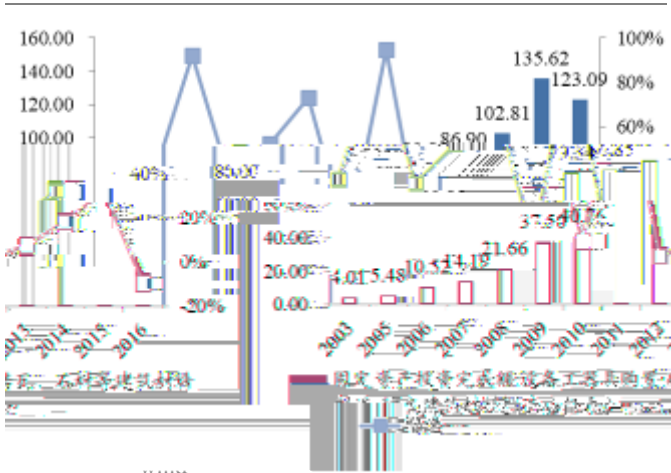

5

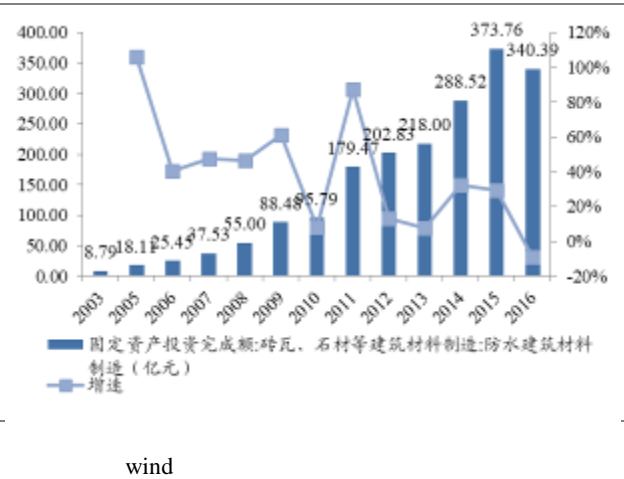

wind

2.1.3.

2000 14,300

34.9% 2014 93.38%

15%

2000 65.1% 7%

SBS/APP

39.4% 20.4% 14.6%

13.2%

SBS/APP

27%



2005

2010

2011

2012

2013

2014

2015

	m2	4,300	1,800	1,701	-6%	1,701	0%	1,701	0%	1,701	0%	1,701	0%
	m2	24,000	11,620	11,801	2%	11,211	-5%	10,202	-9%	9,376	-8%	8,813	-6%

2014

1-11

2015

) 200



50% 1000 /

3.

3.1.

A 2016 60

7

2

		2017	2016				
1		102.93	70		SBS/APP	2.2	70
					TPO	3	
2		18.17	15.78		SBS	41	
						1.5	
						8	
3		20.39	14.73			1	
						10	
						1000	20

4		12.01	10.52			7000	
							TPO PVC
							500 3
							1.3
5							
6		5.27	5.06			1	5
						600	
7		3.94	2.69		SBS/APP	4400	27200
8		0.12	0.56				
9		0.71	0.55				2000
						2	
10			0.35				
11		0.1	0.13				2

2015

10.00

98

K K

TTB

8

3

OEM

351.00

98

Silka)

PVC

PVC

--

--

ICOPAL

07

wind

2015

18.5%

3.2.

ROE

ROE 10% 17%

ROE 10% 17%

ROE

0.6 0.8

10%

2017

40%

" "

9 ROE

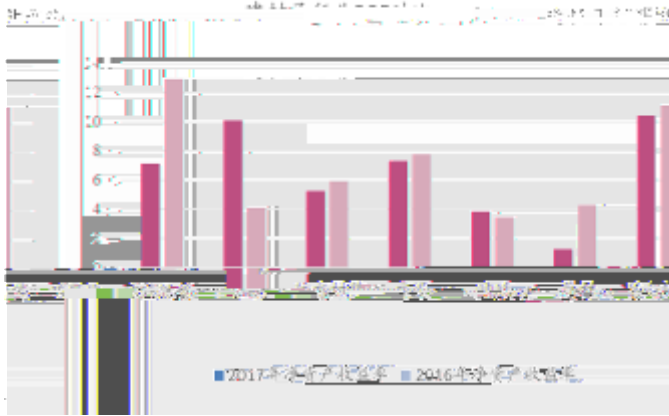

wind

ROE

10

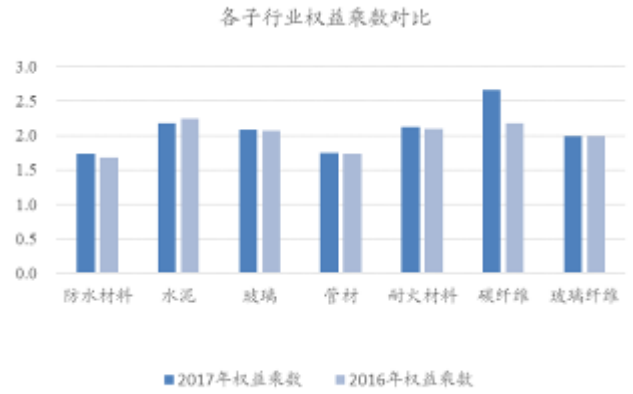

wind

11

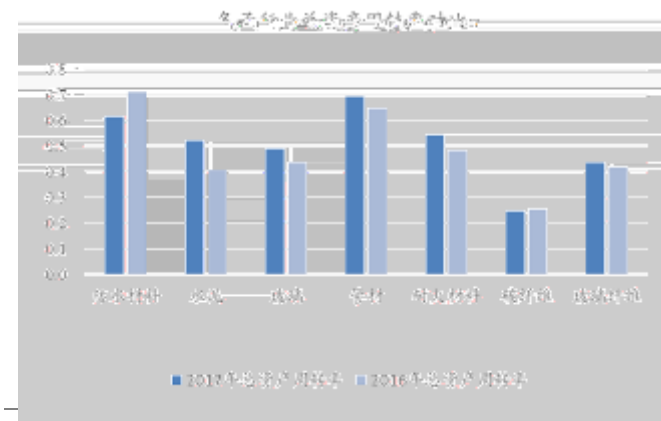

wind

12

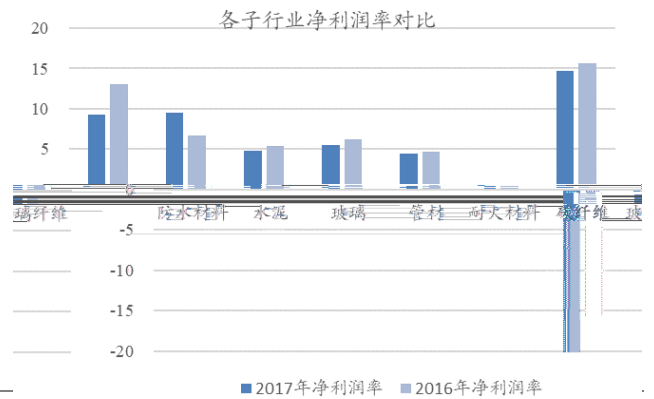

wind

ROE

2

ROE

20%

10%

ROE

ROE

13

ROE

净资产收益率对比变化



14

毛利率对比变化

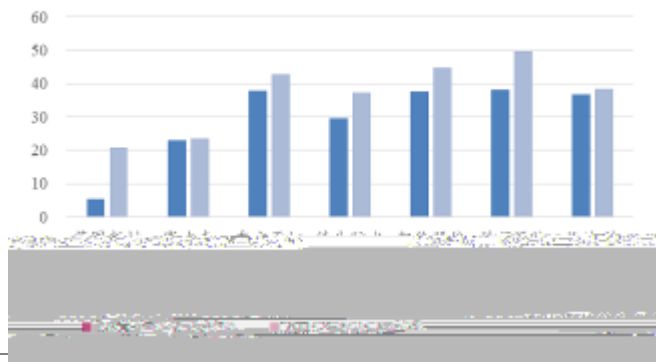

wind

15

净利率对比变化

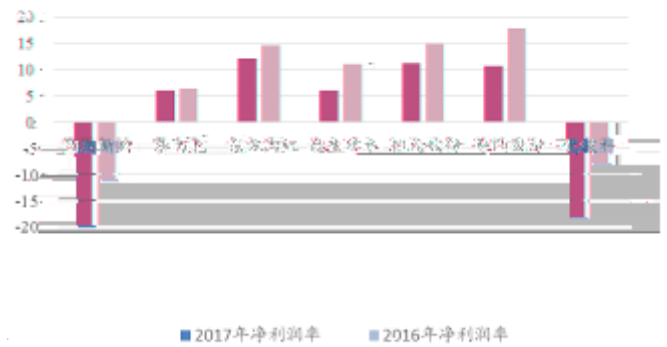

wind

16

权益乘数对比变化

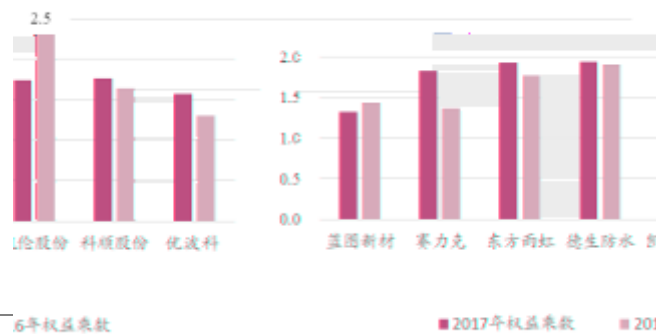

6年权益乘数

2017年权益乘数 2016年权益乘数

17

总资产周转率对比变化

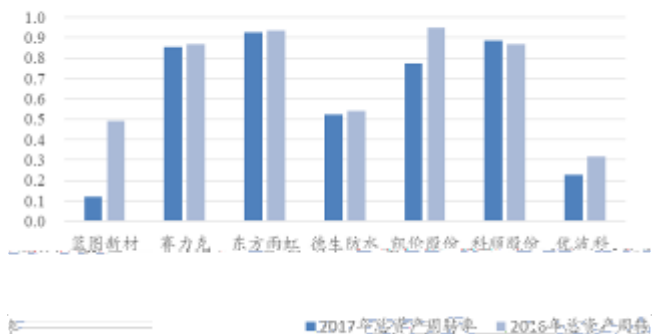

2017年总资产周转率 2016年总资产周转率

2010 30%

2009-2011

6

□ 2012

" "

5-6

2015

12

2

1

2

3

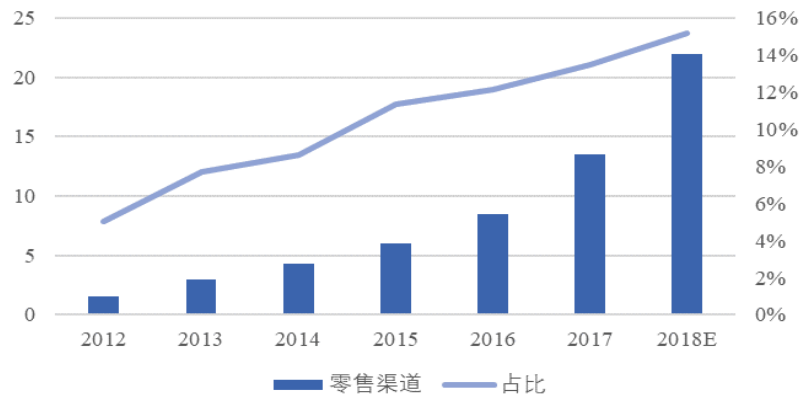

Wind

4

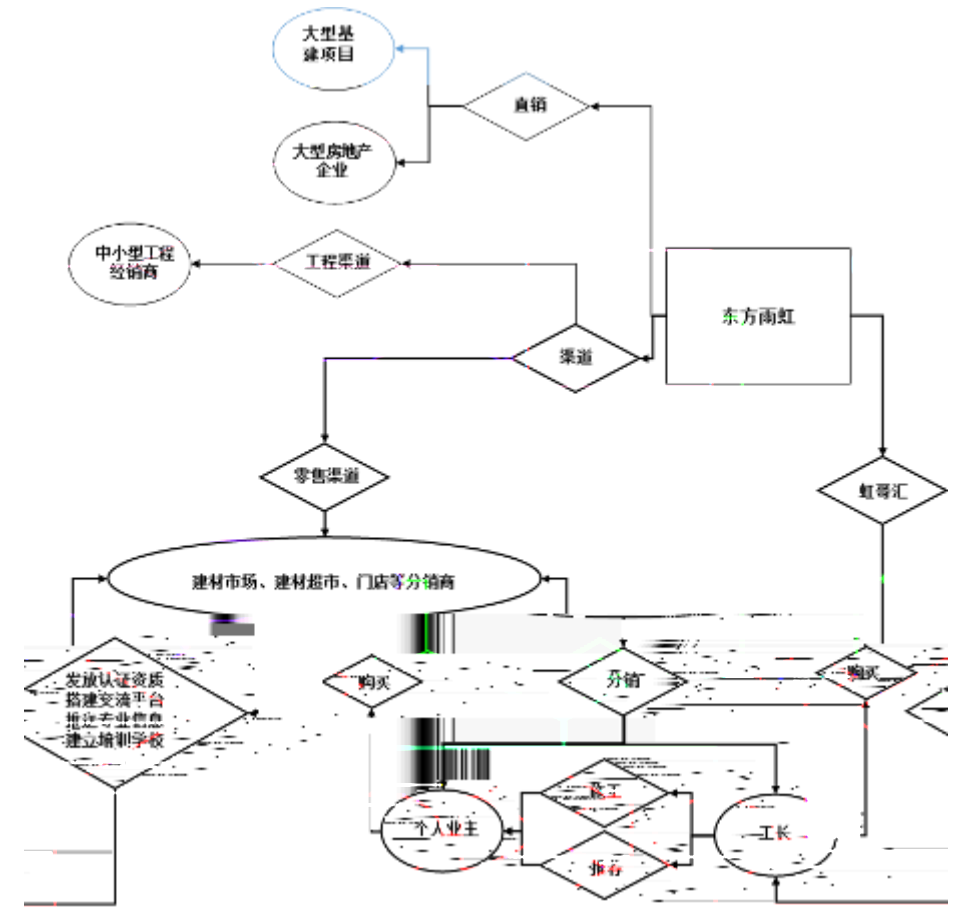

5



21

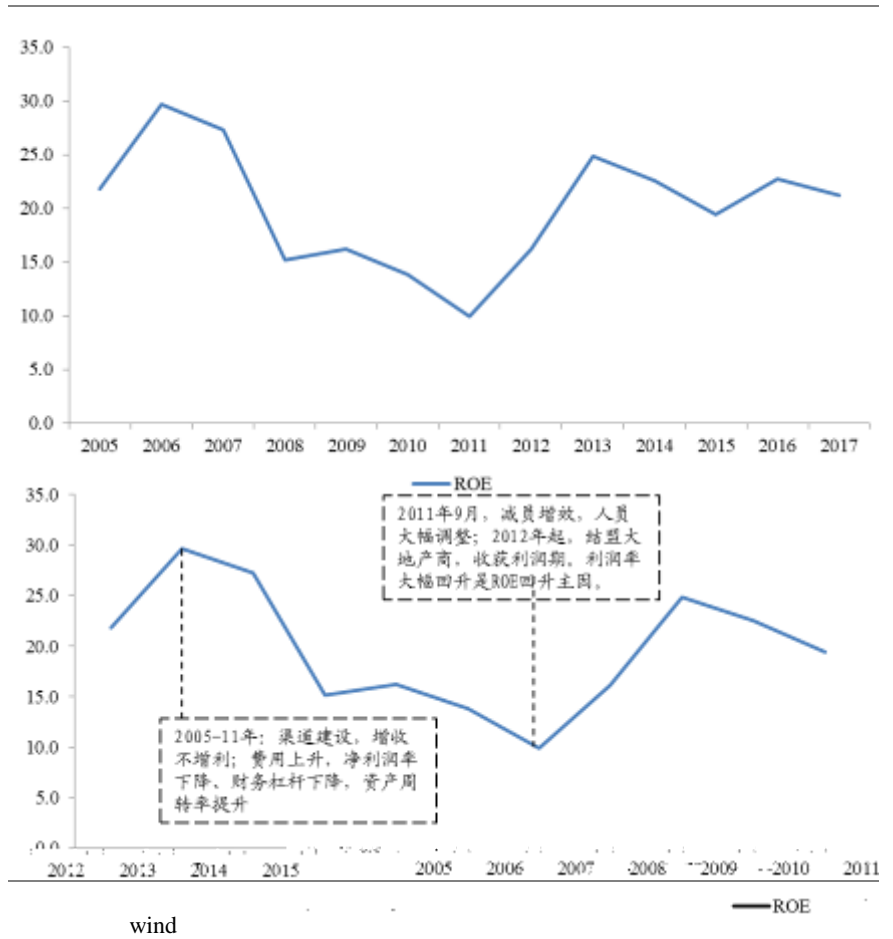

22

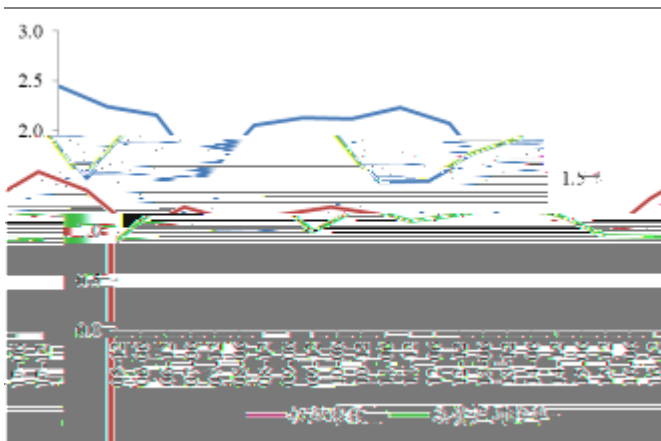

24

ROE ROCE2010

23

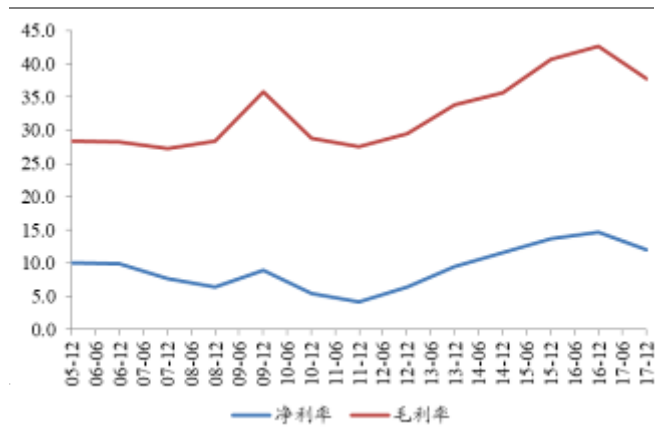

25

ROS

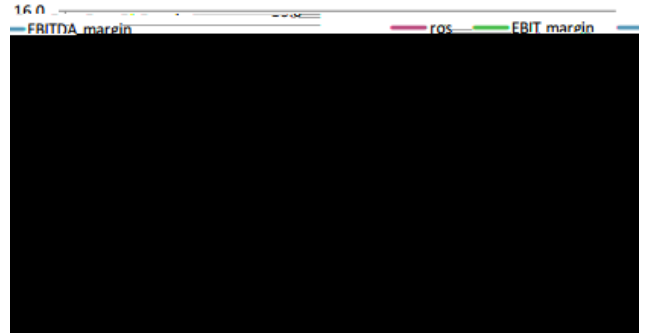
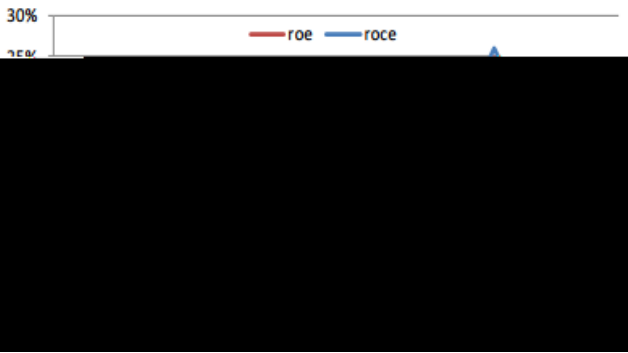

26



27

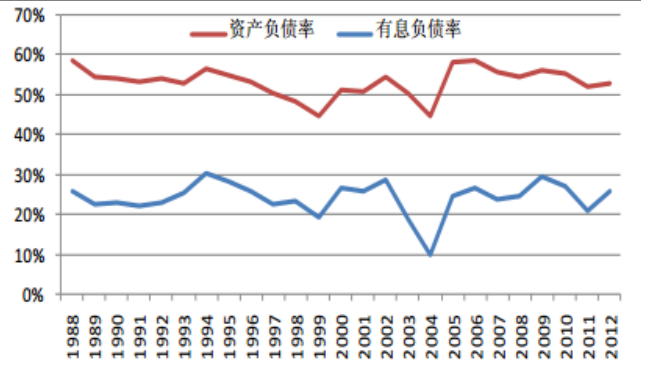

28

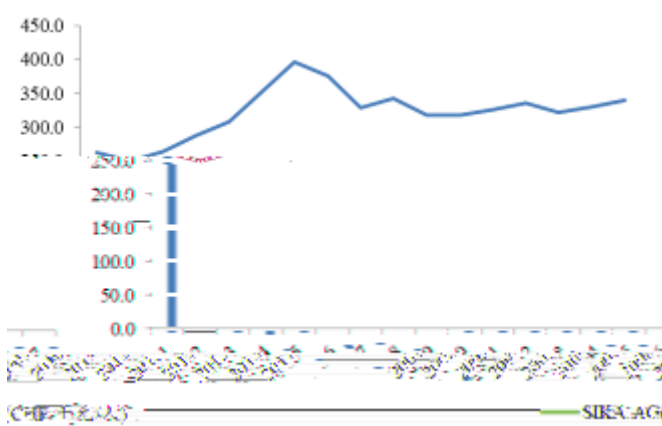

29



5.

wind

31 PE TTM

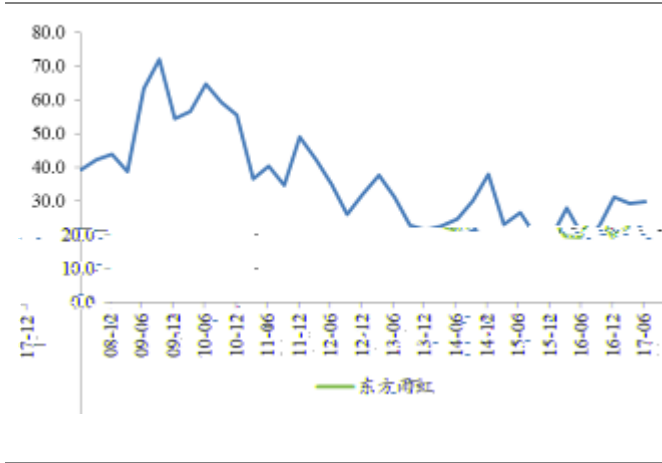

wind

32 PE TTM

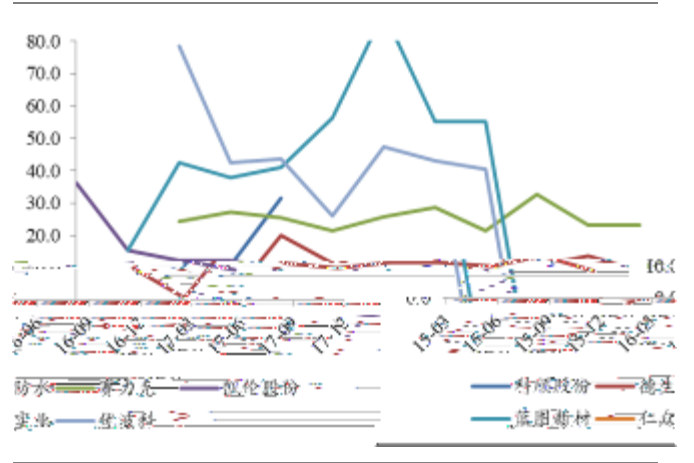

wind

33 07 PE

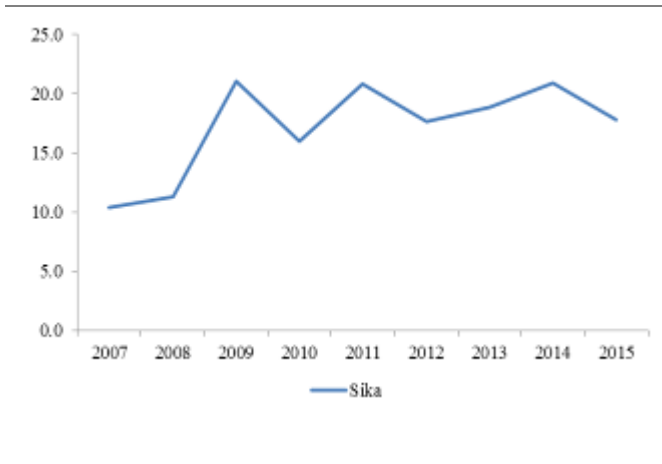

wind

34 PE TTM

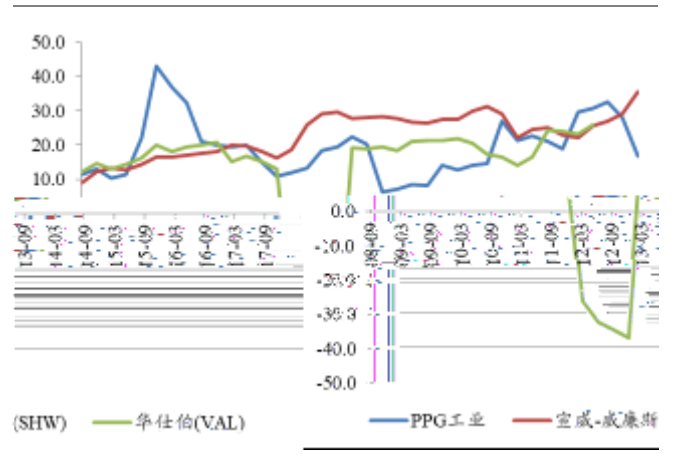

wind

6.

6.1.



20 30

70

TPO

90%

1

15

40

100

2

SBS

APP

TPO

TPO

3

80%

TPO PVC

SBS

80%

APP

90%

SBS APP

4

6.2.

36



6.2.1.

1 80

2

SBS APP

SBS

APP

PE

(AL)

3 80

TPO

TPO

EPDM PVC

6.2.2.

50 60 70

37

